

◆ ◆ ◆ ◆ ◆
◆ ◆ ◆ ◆ ◆

Instruction manual

◆ ◆ ◆ ◆ ◆
◆ ◆ ◆ ◆ ◆

General instructions digital Mass Flow / Pressure instruments laboratory style / IN-FLOW

Doc. no.: 9.17.022AF Date: 06-04-2021

◆ ◆ ◆ ◆ ◆
◆ ◆ ◆ ◆ ◆
◆ ◆ ◆ ◆ ◆
◆ ◆ ◆ ◆ ◆

ATTENTION

**Please read this instruction manual carefully before installing and operating the instrument.
Not following the guidelines could result in personal injury and/or damage to the equipment.**

◆ ◆ ◆ ◆ ◆
◆ ◆ ◆ ◆ ◆

SCOPE OF THIS MANUAL

This manual covers the general part of digital mass flow / pressure instruments for gases or liquids. It handles the general instructions needed for the instruments.

More information can be found in other documents.

Multibus instruments have modular instruction manuals consisting of:

- **General instructions digital Mass Flow / Pressure instruments laboratory style / IN-FLOW (document no. 9.17.022)**
- Operation instructions digital instruments (document no. 9.17.023)
- Fieldbus/interface description:
 - FLOW-BUS interface (document no. 9.17.024)
 - PROFIBUS DP interface (document no. 9.17.025)
 - DeviceNet interface (document no. 9.17.026)
 - RS232 interface with FLOW-BUS protocol (document no. 9.17.027)
 - Modbus interface ASCII / RTU / TCP (document no. 9.17.035)
 - EtherCAT interface (document no. 9.17.063)
 - PROFINET interface (document no. 9.17.095)
 - CANopen interface (document no. 9.17.131)
 - EtherNet/IP interface (document no. 9.17.132)
 - POWERLINK interface (document no. 9.17.142)

Even though care has been taken in the preparation and publication of the contents of this manual, we do not assume legal or other liability for any inaccuracy, mistake, misstatement or any other error of whatsoever nature contained herein. The material in this manual is for information purposes only, and is subject to change without notice.

Warranty

The products of Bronkhorst are warranted against defects in material and workmanship for a period of three years from the date of shipment, provided they are used in accordance with the ordering specifications and the instructions in this manual and that they are not subjected to abuse, physical damage or contamination. Products that do not operate properly during this period may be repaired or replaced at no charge. Repairs are normally warranted for one year or the balance of the original warranty, whichever is the longer.

See also paragraph 9 of the Conditions of sales.

The warranty includes all initial and latent defects, random failures, and undeterminable internal causes.

It excludes failures and damage caused by the customer, such as contamination, improper electrical hook-up, physical shock etc.

Re-conditioning of products primarily returned for warranty service that is partly or wholly judged non-warranty may be charged for.

Bronkhorst High-Tech B.V. prepays outgoing freight charges when any party of the service is performed under warranty, unless otherwise agreed upon beforehand. However, if the product has been returned collect to Bronkhorst High-Tech B.V., these costs are added to the repair invoice. Import and/or export charges, foreign shipping methods/carriers are paid for by the customer.

Short-Form Operation Instruction

Before installing your Mass Flow or Pressure Meter/Controller it is important to read the attached label and check:

- flow/pressure rate
- fluid to be metered
- up- and downstream pressures
- input/output signal

Check the red-coloured sticker and make sure the test pressure is in agreement with normal safety factors for your application.

Check if the piping system is clean. For absolute cleanliness always install filters to assure a clean, moisture- and oil-free gas stream.

Install the Meter/Controller in the line and tighten the fittings according to the instructions of the supplier of the fittings. Choose the mounting position according to the directions given in this manual.

Check the system for leaks before applying fluid pressure

In systems with corrosive or reactive fluids, purging with an inert gas is absolute necessary before use. Complete purging after use with corrosive or reactive fluids is also required before exposing the system to air.

Electrical connections must be made with a standard cable or according to the hook-up diagram in the back of this manual.

Short form start-up

Install instrument in your process.
Provide instrument with correct pressure(s)

! Caution

If the instrument is not performing as expected please contact Bronkhorst High Tech B.V. or your distributor for instructions.

Analog operation

Connect the instrument to the power supply/readout unit with the 9-pin cable at the DB-9 connector / 8 DIN connector

BUS/digital operation

For this procedure: See description for specific fieldbus

Send a setpoint to the instrument and check the measured value

Let the instrument warm-up for 30 minutes for best accuracy

Your Mass Flow/Pressure Meter/Controller is now ready for operation.

! Caution

Operation via fieldbus is done by means of a flat conductor cable connected with the main PC board. Although all functionality is possible by means of RS232 and the switch on top of the instrument, it is important that care should be taken when removing the upper part of the housing.

Safety Precautions

The following safety precautions should be observed before using this product and any associated instrumentation.

This product is intended for use by qualified personnel who recognize shock hazards and are familiar with the safety precautions required to avoid possible injury. Read the operating information carefully before using the product.

Before operating, make sure the line cord is connected to a properly grounded power receptacle. Inspect the connecting cables, test leads, cracks, or breaks before each use.

The module and accessories must be used in accordance with its specifications and operating instructions or the safety of the equipment may be impaired.

If required, replace fuses with the same type and rating for continued protection against fire hazard.

Opening of the equipment is not allowed. There are no repairable parts inside. In case of a defect please return the equipment to Bronkhorst High-Tech.



The symbol  on an instrument indicates that the user should refer to the operating instructions located in the manual.



Surfaces near the  symbol may be hot.

To maintain protection from electric shock and fire, replacement components must be obtained from Bronkhorst High-Tech B.V. Standard fuses, with applicable national safety approvals, may be used if the rating and type are the same. Other components that are not safety related may be obtained from other suppliers as long as they are equivalent to the original component. (Note that selected parts should be obtained only through Bronkhorst to maintain accuracy and functionality of the product.) If you are unsure about the applicability of a replacement component, call a Bronkhorst® office for information.

TABLE OF CONTENTS

1	Introduction	9
1.1	General description.....	9
1.1.1	Gas flow.....	9
1.1.2	Liquid flow.....	9
1.1.3	Pressure	9
1.1.4	Housings.....	9
1.1.5	Valves.....	11
1.2	Sensor principles	12
1.2.1	Gas flow sensors (by-pass measurement).....	12
1.2.2	Gas flow sensors (direct mass flow measurement, CTA based)	12
1.2.3	Liquid flow sensors	12
1)	The μ -FLOW model for flowrates up to 2 g/h.....	12
2)	The CTA based LIQUI-FLOW™ series L10 / L20 model for flow rates up to approximately 1000 g/h. .	13
1.2.4	Pressure sensor	13
1.3	Valve principles.....	13
1.3.1	Solenoid valve	13
1.3.2	Vary-P valve	13
1.3.3	Pilot operated valve	14
1.3.4	Bellows valve.....	14
1.4	K _v -value calculation	14
1.4.1	For gases.....	14
1.4.2	For liquids	15
1.4.3	Maximum pressure drop.....	16
1.5	Sensors and laminar flow devices	16
1.6	Conversion factors.....	17
1.6.1	Gas conversion factors (by-pass measurement).....	17
1.6.2	Gas Conversion Factors (direct mass flow measurement, CTA-based).....	18
1.6.3	Liquid Conversion Factors.....	19
1.6.4	Software for conversion factor calculation.....	19
2	Installation.....	20
2.1	Receipt of equipment.....	20
2.2	Return shipment.....	20
2.3	Service	20
2.4	Mounting	21
2.5	In-line filter	21
2.6	Fluid connections	22
2.7	Piping.....	22
2.8	Electrical connections	22
2.8.1	Disconnection from supply source	23
2.9	Caution.....	23
2.10	Supply pressure	23
2.11	System purging	23
2.12	Seals	23
2.13	Equipment storage.....	24
2.14	Electromagnetic compatibility.....	24
2.14.1	Conditions for compliance with EMC requirements	24
3	OPERATION	26
3.1	General	26
3.2	Power and warm-up.....	26
3.3	Zeroing.....	26
3.4	Start-up	27
3.5	Operating conditions.....	27
3.6	Instrument performance.....	27
3.6.1	Sensors.....	27
3.6.2	Controllers	27
3.7	Manual operation	28
3.8	Analog operation.....	28
3.9	BUS / digital operation	29
4	Maintenance.....	30
4.1	General	30

4.2	Gas flow sensor	30
4.3	Liquid flow sensor	30
4.4	Pressure sensor	30
4.5	Controllers	30
4.6	Control valves	30
4.6.1	Solenoid valves	30
4.6.2	Vary-P valve	31
4.6.3	Pilot operated valve	31
4.6.4	Bellows valve	31
4.7	Calibration procedure	31
4.8	Cleaning	31
5	Digital instrument	32
6	Interface description	33
7	TROUBLESHOOTING	34
7.1	General	34
7.2	Troubleshooting summary general	35

Appendices

1	Gas conversion table
2	Enclosures (if applicable)

1 Introduction

1.1 General description

1.1.1 Gas flow

The Bronkhorst® series mass flow meter for gases is an accurate device for measuring gas flows up to 700 bar depending on body rating, virtually independent of pressure and temperature changes. The system can be completed with a control valve and flexible readout to measure and control gas flows from 1 ml_n/min up to several thousand m³_n/h, depending on the specific type of instrument. For limited flow ranges a metal sealed model is available.

1.1.2 Liquid flow

The Bronkhorst® mass flow meter for liquids is an accurate device for measuring liquid flows up to 400 bar depending on body rating, virtually independent of pressure and temperature changes. The system can be completed with a control valve to measure and control liquid flows from 2g/h up to 1000g/h.

1.1.3 Pressure

The Bronkhorst® pressure meter measures pressures from 100 mbar up to 400 bar depending on body rating, either absolute pressure or gauge pressure and in the range 0 to 15 bar differential pressure too. The pressure controller controls pressure with a very high accuracy and repeatability. The controller is available in forward control (P-600 series) and backward control (P-700 series) and process pressure control (P-800 series). The flow going through the pressure controller depends on up and downstream pressures, the orifice diameter of the valve and kind of fluid.

1.1.4 Housings

Each instrument housing style incorporates several provisions to comply with EMC requirements.

EL-FLOW®, EL-PRESS

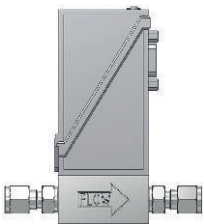

The p.c.board is placed in a metalized plastic cover. For electrical connection the instrument has a male 9-pin miniature sub-D connector for analog/RS232 operation. For digital operation the instrument has various connectors on top. These instruments are suited for dry (indoor) applications, like laboratories and in well protected (OEM) housings.

EL-FLOW®, EL-PRESS metal seal

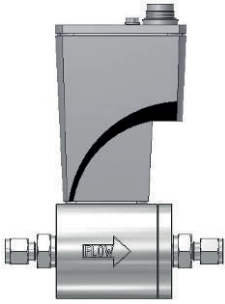

This series has the same housing as the standard EL-FLOW®, EL-PRESS series, but this series distinguishes itself by metal-to-metal seals.

IN-FLOW , IN-PRESS

To comply with the IP65 ingress protection standard, the p.c. board is housed in a sealed casted metal housing. For electrical connections the instrument has a 8DIN male connector for analog/RS232 operation and for digital operation various connectors on top. These instruments are suited for light industrial (outdoor) use to IP65.

LIQUI-FLOW

Two different digital-liquid flow meters can be distinguished:

μ-FLOW model

The μ-FLOW model for up to 2 g/h, basically a straight capillary tube with a sensor. For electrical connection the instrument is equipped with a male 9-pin sub D-connector. The instrument is suited for dry (indoor) applications like laboratories.

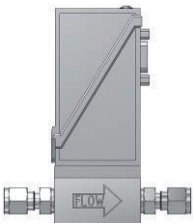
CTA based LIQUI-FLOW™ series L10 / L20

The CTA based LIQUI-FLOW™ series L10 / L20 model for flow rates up to approximately 1000 g/h. For electrical connection the instrument is equipped with a male 9-pin sub D-connector. The instrument is suited for dry (indoor) applications like laboratories.



To comply with the IP65 ingress protection standard, the p.c. board is housed in a sealed casted metal housing. For electrical connections the instrument has a 8DIN male connector for analog/RS232 operation and for digital operation various connectors on top. These instruments are suited for light industrial (outdoor) use to IP65.

1.1.5 Valves

Laboratory style

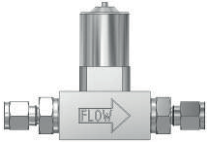

For gases:
The solenoids of these valves have an IP50 ingress protection class.
This means that the valves are suited for dry (indoor) use.



For liquids:
The solenoids of these valves have an IP50 ingress protection class.
This means that the valves are suited for dry (indoor) use.
This valve is equipped with a purge connector.

Industrial style

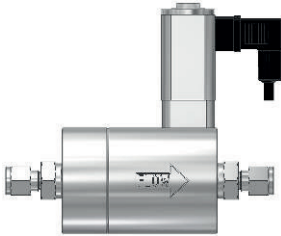

For gases:
The solenoids of these valves have an IP65 ingress protection class. This means that they are suited for light industrial (outdoor) use.

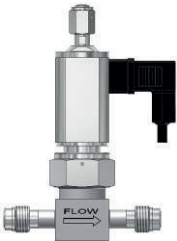

For liquids:
The solenoids of these valves have an IP65 ingress protection class. This means that they are suited for light industrial (outdoor) use.
This valve is equipped with a purge connector.

1.2 Sensor principles

1.2.1 Gas flow sensors (by-pass measurement)

The majority of gas flow sensors operate according to the by-pass measurement principle. These types of instruments operate on a principle of heat transfer by sensing the delta-T along a heated section of a capillary tube. Part of the total flow is forced through the capillary by means of a laminar flow device in the main stream generating a delta-p.

The design of the laminar flow device is such that flow conditions in both the capillary and laminar flow device are comparable, thereby resulting in proportional flow rates through the meter. The delta-T sensed by the upstream and downstream temperature sensors on the capillary depends on the amount of heat absorbed by the gas flow.

The transfer function between gas mass flow and signal can be described by the equation:

V_{signal} = output signal

c_p = specific heat

K = constant factor

Φ_m = mass flow

$$V_{\text{signal}} = K \cdot c_p \cdot \Phi_m$$

The temperature sensors are part of a bridge circuit and the imbalance is linearised and amplified to the desired signal level.

1.2.2 Gas flow sensors (direct mass flow measurement, CTA based)

The IN-FLOW CTA models operate on the principle of direct thermal mass flow measurement. The thru-flow design sensor consists of a heater resistor and a temperature sensing resistor. Both resistors are made of temperature sensitive resistive material that is covered with a stainless steel tube. The heating power required to keep the temperature difference between the heater resistor and the sensing resistor at a constant level is proportional to the mass flow. A different and unique heater current is produced for each value of the flow. The measurement principle described is called Constant Temperature Anemometry (CTA).

The transfer function between mass flow and output signal can be described by the equation:

$$S_{\text{signal}} \cong S_0 + K \cdot \Phi_m^n$$

S_{signal} = output signal

S_0 = offset (zero flow) signal

K = constant factor (includes λ – heat conductivity, C_p – specific heat, μ – dynamic viscosity and ρ – density of the gas)

Φ_m = mass flow

n = dimensionless constant (typically of order 0.5)

1.2.3 Liquid flow sensors

Two digital-liquid flow measurements and two sensor arrangements can be distinguished. They have in common that there is no bypass system involved, which means that they are of the type: “thru flow”. The following sensor arrangements can be distinguished:

1) The μ -FLOW model for flowrates up to 2 g/h.

Basically this is a small capillary tube with two sensing elements placed on the tube. The two elements both serve as heater as well as temperature sensing elements. The delta-T sensed by the upstream and downstream temperature sensors on the capillary depends on the amount of heat absorbed by the mass of the liquid. The temperature sensors are part of a bridge circuit and the unbalance is amplified to the desired signal level. The transfer function between liquid mass flow and signal can be described by the equation:

V_{signal} = output signal

c_p = specific heat

K = constant factor

Φ_m = mass flow

$$V_{\text{signal}} = K \cdot c_p \cdot \Phi_m$$

2) The CTA based LIQUI-FLOW™ series L10 / L20 model for flow rates up to approximately 1000 g/h.

The CTA based LIQUI-FLOW™ series L10 / L20 model basically consists of a small capillary tube with two sensing elements placed around it. The upstream sensing element is a temperature sensor that is used to measure the temperature of the liquid flowing through the tube. The downstream sensing element is a heater, which is heated up to a certain temperature ΔT over the medium temperature. A patent application on the flow sensor design has been submitted.

The heater power necessary to keep ΔT at a constant level is dependent on the mass flow. In the case of no flow, a constant and negligibly small heating power is necessary. When a certain mass flow occurs, the heater is cooled down. Therefore, the heating power has to be increased to maintain the adjusted temperature difference. Thus, a different and unique heater power is produced for each value of the flow.

The measurement principle described is called Constant Temperature Anemometry (CTA).

The heater and temperature sensing element are electrically connected via a Wheatstone bridge configuration that performs two features: first, it provides the heater with the necessary heater power and second, it takes care of the temperature compensation. Finally, a signal conditioning circuit provides a linear output signal. The transfer function between the liquid mass flow and the linear output signal can roughly be described with the equation:

V_{signal} = output signal

K = calibration constant

$$V_{\text{signal}} \cong K \cdot c_p \cdot \lambda^2 \cdot \Phi_m$$

c_p = specific heat

λ = heat conduction coefficient

Φ_m = mass flow

1.2.4 Pressure sensor

The EL-PRESS / IN-PRESS pressure sensor is formed by a piezo-resistive bridge on the surface of a silicon crystal. The sensor is mounted in a stainless steel construction and separated from the fluid by a thin metal membrane. The chamber around the sensor is filled with oil to couple the pressure from the fluid to the sensor.

1.3 Valve principles

Control valves are not designed to provide positive shut-off, although some models have excellent capabilities for this purpose.

It is recommended to install a separate shut-off valve in the line if so required. Also pressure surges, as may occur during system pressurisation must be avoided. The following models can be distinguished:

1.3.1 Solenoid valve

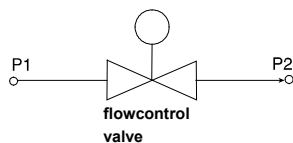

This is considered to be the standard (direct operated) control valve. In general it is a normally closed solenoid valve. The plunger is lifted by the force of the magnetic field of the coil. The orifice under the plunger is removable for optimising the orifice diameter. Also a normally opened solenoid valve is available.

1.3.2 Vary-P valve

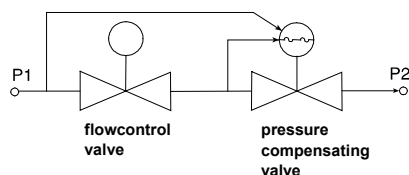

For process conditions where up- and downstream pressure vary much, a special type of valve, VARY-P has been designed. This valve consists of two valves, a solenoid operated control valve and a fixed adjusted pressure compensation valve.

1.3.3 Pilot operated valve

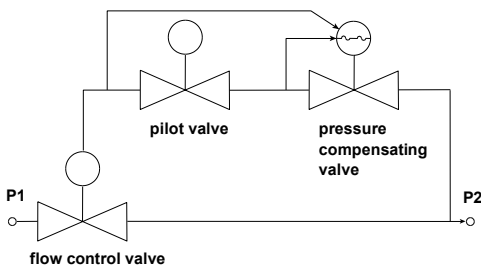

For high flow rates the pilot operated valve has been designed. A solenoid driven control valve controls the pressure difference across a piston, which lifts the main plunger.

1.3.4 Bellows valve

This valve type is a direct driven, low power, solenoid operated control valve. A special design, incorporating a metal bellows allows for a relatively large orifice opening to be controlled. The design is suited for low pressure or vacuum applications.

1.4 *K_v*-value calculation

This calculation method can be used to determine the *K_v*-value of the main orifice of a control valve.

1.4.1 For gases

Determine desired Δp across valve.

Δp must be at least 20% of supply pressure, or in closed loop systems, of total pressure difference in loop.

If Δp is 20-50% of supply pressure, use formula:

$$K_v = \frac{\Phi_{vn}}{514} \sqrt{\frac{\rho_n \cdot T}{\Delta p \cdot p_2}}$$

undercritical

If ΔP is 50-100% of supply pressure, use formula:

$$K_v = \frac{\Phi_{vn}}{257 \cdot p_1} \sqrt{\rho_n \cdot T}$$

overcritical

Units:

Φ_{vn} = flow [m_n^3/h]

p_1 = supply pressure [bara]

p_2 = downstream pressure [bara]

Δp = pressure difference ($p_1 - p_2$) [bara]

T = temperature [K]

ρ_n = density [kg/m_n^3]

The orifice diameter can be determined by:

$$d = 7.6 \sqrt{K_v} \text{ [mm]}$$

1.4.2 For liquids

This calculation method can be used to determine the K_v -value of the main orifice of a control valve.

$$K_v = \Phi_v \sqrt{\frac{\rho}{\Delta p \cdot 1000}}$$

Units:

Φ_v = volume flow [m³/h]

ρ = density at 20°C and 1 atm [kg/m³]

Δp = delta p [bard]

The orifice bore diameter can be determined by:

$$d = 7.6 \sqrt{K_v} \text{ [mm]}$$

On LFC's only one type of normally closed valve is available. Diameter of orifice can be calculated or looked up in the table.

Diameter [mm]	K_v	Normally closed Δp max. [bard]
0,10	$1,73 \times 10^{-4}$	10
0,14	$3,39 \times 10^{-4}$	10
0,20	$6,93 \times 10^{-4}$	10
0,30	$1,56 \times 10^{-3}$	10
0,37	$2,37 \times 10^{-3}$	10
0,50	$4,33 \times 10^{-3}$	10
0,70	$8,48 \times 10^{-3}$	10
1,00	$1,73 \times 10^{-2}$	10

* For liquids having a dynamic viscosity: $15 \text{ cP} < \mu < 100 \text{ cP}$ the K_v value should be calculated according to:

$$K_v = \Phi_v \sqrt{\frac{\rho}{\Delta p \cdot 1000}} \cdot \sqrt{\mu}$$

Units:

Φ_v = volume flow [m³/h]

ρ = density at 20°C and 1 atm. [kg/m³]

Δp = delta p [bard]

μ = dynamic viscosity [cP]

For maximum possible viscosity apply to factory

1.4.3 Maximum pressure drop

For (pilot) solenoid operated control valves with small orifices the maximum allowable pressure drop for gases is according to the table.

Diameter [mm]	K_v	Normally closed Δp max. [bard]	Normally opened Δp max. [bard]
0,05	$4,33 \times 10^{-5}$	40	30
0,07	$8,48 \times 10^{-5}$	30	20
0,10	$1,73 \times 10^{-4}$	30	20
0,14	$3,39 \times 10^{-4}$	30	20
0,20	$6,93 \times 10^{-4}$	30	20
0,30	$1,56 \times 10^{-3}$	30	20
0,37	$2,37 \times 10^{-3}$	30	20
0,50	$4,33 \times 10^{-3}$	30	20
0,70	$8,48 \times 10^{-3}$	24	15
1,00	$1,73 \times 10^{-2}$	12	8
1,30	$2,93 \times 10^{-2}$	8	5
1,50	$3,90 \times 10^{-2}$	6	n.a.
1,70	$5,00 \times 10^{-2}$	5	n.a.
2,00	$6,63 \times 10^{-2}$	3,6	n.a.

For pilot operated valves the maximum pressure drop is limited to 20 bard. If the pressure drop during start-up is higher, it is preferred to install a bypass valve. During start-up this valve should be opened. Also the minimum pressure drop is limited. For exact figures consult factory or proceed according to the technical data and/or additional instructions given by the sales office or department.

1.5 Sensors and laminar flow devices

Flow devices are used to determine the total flow rate of a gas flow meter or controller.

Mind that liquid flow sensors, CTA-based sensors and pressure sensors do not require a flow device.

Depending on the application the flow sensors have different removable capillaries, requiring a different laminar flow device.

Furthermore for flow rates higher than 1250 l_n/min the main laminar flow device is used in combination with a capillary / flow device arrangement in order to compensate for the non ideal transfer function of the main flow device.

In general 3 types of capillary tubes are available:

- Small bore (C-type)

The following notes apply to this type of sensor:

- These sensors have a pressure drop of approx. 35 mbar
- The laminar flow device consists of a stack of discs with precision etched flow channels. Each flow channel represents approx. 10 ml_n/min airflow at 35 mbar delta-P.
- In all instruments with a pressure rating above 100 bar (M-type) the sensor is fitted with metal seals.
- In general instruments with these sensors may be mounted horizontal, as well as in a vertical position, at low operating pressures. At high pressures (>10 bar) the instruments should be mounted in a horizontal position.
- The EL-FLOW, EL-PRESS metal seal series are fitted with a metal sealed sensor.

- Large bore (D-type)

To this type of sensor the following remarks apply:

- These sensors are preferably used for reactive gases and at low pressure applications.
- The pressure drop is less than 0.5 mbar.
- The laminar flow device forms together with the main channel an annular channel. The dimensions of this annular channel determine the flow capacity of the instrument.
- The instrument must always be mounted in a horizontal position.

- Medium bore (E-type)

This sensor is used in the "EL-FLOW series" and is used for increasing the flow range of the "low deltaP series". The same remarks as the D-type apply to this sensor, only:

- The pressure drop is approx. 2.5 mbar.

1.6 Conversion factors

1.6.1 Gas conversion factors (by-pass measurement)

The general formula for determining the relationship between signal and mass flow is:

$$V_{\text{signal}} = K \cdot c_p \cdot \Phi_m = K \cdot c_p \cdot \rho \cdot \Phi_v$$

in which:

V_{signal}	= output signal
K	= constant
ρ	= density
c_p	= specific heat
Φ_m	= mass flow
Φ_v	= volume flow

As soon as the c_p value and density of the gas to be metered change, the signal must be corrected. The conversion factor C is:

$$C = \frac{c_{p1} \cdot \rho_1}{c_{p2} \cdot \rho_2}$$

in which:

c_p	= specific heat
ρ_n	= density at normal conditions

- (1) gas calibrated
- (2) gas to be measured

Note:

The c_p value used for the calculation of the conversion factor must be taken at a temperature approx. 50°C. higher than the required temperature.

This factor is called c_p cal.

The conversion factors for commonly used gases related to N_2 at normal conditions are stated in the Gas Conversion Table in the appendix 1.

Example:

Meter calibrated on N_2 (200 ml_n/min).

Gas flow passing the meter is CO_2 .

Output signal reads 80.0%.

$$\text{Actual } CO_2 \text{ flow} = 80.0 \cdot \frac{0.74}{1.00} = 59.2\%$$

$$\text{so } \frac{59.2}{100} \cdot 200 = 118.4 \text{ ml}_n/\text{min}$$

* **n** means **normal conditions**

At normal conditions volumes are converted to a temperature of 0°C and pressure of 1 atm or 1013,25 mbar. (760 Torr)

Note:

Best accuracy is always achieved by performing calibration under operating conditions. Should this not be possible or practical, then the use of a theoretical conversion factor is a means to determine the flow rate of the instrument on the gas to be metered, however, it will introduce inaccuracies.

The approximate accuracy of the conversion factors listed is:

typical for conversion factors; > 1 **2% x factor**
 < 1 **2% / factor**

However, as the accuracy of the factor also depends on viscosity, pressure and temperature, special attention should be taken for gases in the gas/liquid state where specific heat, density and viscosity can vary tremendously. Apply to factory for more detailed information.

For gas mixtures a good approach is the following simplified equation:

$$\frac{1}{C_{mix}} = \frac{V_1}{C_1} + \frac{V_2}{C_2} + \dots + \frac{V_n}{C_n}$$

C_{mix} = Conversion factor for gas mixture
 C_n = Conversion factor for gas n
 V_n = Volumetric part of gas n in the mixture

Example Gas mixture contains:

- (1) 10% N₂ C1 = 1,00
- (2) 30% Ar C2 = 1,40
- (3) 50% CH₄ C3 = 0,76
- (4) 10% He C4 = 1,41

$$\frac{1}{C_{mix}} = \frac{0,10}{1,00} + \frac{0,30}{1,40} + \frac{0,50}{0,76} + \frac{0,10}{1,41} = 1,043$$

$C_{mix} = 0,959$

When the original meter has been calibrated on 500 ml_n/min N₂, 100% means:

$$500 \cdot \frac{0,959}{1,00} = 480 \text{ ml}_n/\text{min mixture.}$$

When the original meter has been calibrated on 500 ml_n/min Argon, then 100% means:

$$500 \cdot \frac{0,959}{1,40} = 343 \text{ ml}_n/\text{min gas mixture.}$$

1.6.2 Gas Conversion Factors (direct mass flow measurement, CTA-based)

For CTA-based gas flow sensors the general relationship between signal and mass flow is:

$$S_{signal} \cong S_0 + K \cdot \Phi_m^n$$

In which:

- S_{signal} = output signal
- S_0 = offset (zero flow) signal
- K = constant factor (includes λ – heat conductivity, C_p – specific heat, μ – dynamic viscosity and ρ – density of the gas)
- Φ_m = mass flow
- n = dimensionless constant (typically of order 0.5)

Due to the offset signal (which is also dependent on fluid properties) and the non-linear relationship between signal and mass flow, a single conversion factor for a custom fluid that covers the entire flow range of an instrument cannot be obtained. However, a complex and partially empirical conversion model is available for

most common gases, which is accurate at both lower and higher flow ranges. Consult Bronkhorst for applications.

At nominal flow ranges for each instrument, a good approximation is the use of the so-called "CFDirect" conversion method, which comes with the FLUIDAT software.

Consult FLUIDAT for the most optimal conversion factor.

1.6.3 Liquid Conversion Factors

1) μ -FLOW models

The general formula for determining the relationship between signal and mass flow reads:

in which:

V_{signal} = output signal

$$V_{\text{signal}} = k \cdot c_p \cdot \Phi_m$$

k = calibration constant

c_p = heat capacity at constant pressure of the fluid

Φ_m = mass flow

A conversion factor must be used if the liquid flow meter is not used on the calibrated liquid.

This conversion factor reads:

in which:

c_{p1} = heat capacity of the calibration liquid

$$\Phi_{m_2} = Cf \cdot \Phi_{m_1}$$

$$Cf = \frac{c_{p1}}{c_{p2}}$$

c_{p2} = heat capacity of the new liquid

For application of this formula consult Bronkhorst High-Tech BV.

2) CTA based LIQUI-FLOW series L10 / L20

For the CTA based LIQUI-FLOW series L10 / L20 liquid mass flow sensor, the transfer function between the liquid mass flow and the linear output signal can roughly be described with the equation:

$$V_{\text{signal}} \cong K \cdot c_p \cdot \lambda^2 \cdot \Phi_m$$

V_{signal} = output signal

K = calibration constant

c_p = specific heat

λ = heat conduction coefficient

Φ_m = mass flow

A conversion factor must be used if the liquid flow meter is not used on the calibrated liquid (reference liquid) but on another liquid (custom liquid). The conversion factor CF can roughly be calculated with the equation:

$$CF \cong \frac{(c_p \lambda^2)_{\text{REFERENCE-FLUID}}}{(c_p \lambda^2)_{\text{CUSTOM FLUID}}}$$

For application of this equation, please consult Bronkhorst High-Tech BV.

1.6.4 Software for conversion factor calculation

Bronkhorst® gathered the physical properties of over 600 fluids in a database called FLUIDAT®.

Application software, such as FLUIDAT® on the Net (FOTN), enable the user to calculate accurate conversion factors, not only at 20°C/1 atm (as shown in the conversion table, App.1) but at any temperature/pressure combination.

Apply to your distributor for more details of this software.

2 Installation

2.1 *Receipt of equipment*

Check the outside packing box for damage incurred during shipment. Should the packing box be damaged, then the local carrier must be notified at once regarding his liability, if so required. At the same time a report should be submitted to:

BRONKHORST HIGH-TECH B.V.
RUURLO HOLLAND

If applicable, otherwise contact your distributor.

Remove the envelope containing the packing list; carefully remove the equipment from the packing box. Do not discard spare or replacement parts with the packing material and inspect the contents for damaged or missing parts.

2.2 *Return shipment*

When returning material, always describe the problem and if possible the work to be done, in a covering letter.

It is absolutely required to notify the factory if toxic or dangerous fluids have been metered with the instrument!

This to enable the factory to take sufficient precautionary measures to safe-guard the staff in their repair department. Take proper care of packing, if possible use the original packing box; seal instrument in plastic etc.

All instruments must be dispatched with a completely filled in 'declaration on contamination form'. Instruments without this declaration will not be accepted.

Note:

If the instruments have been used with toxic or dangerous fluids the customer should pre-clean the instrument.

Important:

Clearly note, on top of the package, the customer clearance number of Bronkhorst High-Tech B.V., namely:

NL801989978B01

If applicable, otherwise contact your distributor for local arrangements.

2.3 *Service*

If the equipment is not properly serviced, serious personal injury and/or damage to the equipment could be the result. It is therefore important that servicing is performed by trained and qualified service personnel. Bronkhorst® has a trained staff of servicemen available.

2.4 Mounting

The mounting position depends on the type of instrument. For flowmeters the preferred position is horizontal, and at high pressures all meters should be mounted in this position. Avoid installation in close proximity of mechanic vibration and/or heat sources.

Mount instruments using the threaded mounting holes at the bottom of the instrument, as indicated in the applicable dimensional drawing. Use stainless steel bolts with minimum strength class 70 (not included). The recommended torque values can be found in the table below.

Recommended torque in Nm for stainless steel bolts with strength class 70						
Bolt size	M4	M5	M6	M8	M10	M12
Torque [Nm]	2.0	4.1	7.0	17.0	33.0	57.0

For mounting the F-106/F-107 series handle the following rules:

STRAIGHT PIPE LENGTH REQUIREMENTS (in number of diameters F)

	Upstream	Downstream
one 90° bend before meter	10	4
two 90° bend before meter	13	4
two 90° bend in two planes	20	4
three 90° bend in three planes	30	4
reduction before meter	10	4
expansion before meter	20	4
pressure reducing valve / control valve / partially closed valve before meter	30	4

For further information see dimensional drawing.

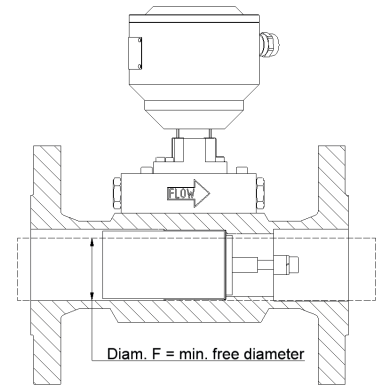

In general flow straighteners have a suspicious influence on the free length of the meter. A flow straightener can be imagined as a bundle of parallel tubes which is placed in the tube.

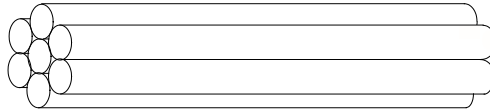

In general, these flow straighteners must be placed at least 6 à 8 D upstream of the meter. In general, use a flow straightener in case of control valves and curves in unequal levels.

Next to these prescriptions for free length, the flow has to be steady, shock and pulsation free.

2.5 In-line filter

Although fluids to be measured should be absolutely free of dirt, oil, moisture and other particles, it is recommended to install an in-line filter upstream of the flowmeter / controller, and if backflow can occur, a downstream filter is recommended too. Be aware of the pressure drop caused by the filter.

On the inlet of some instruments a screen is placed to prevent foreign matter from entering the instrument and to maintain a good flow pattern. This device **cannot** be seen as a filter element.

Contact your distributor for further information.

2.6 Fluid connections

Bronkhorst® meters / controllers are equipped with compression type or face-seal-fittings. For most of the instruments these fittings are BSP parallel threads types which have to be used in combination with elastomeric O-rings to seal to the instrument. For some instruments these fittings are orbital welded to the body. For leak tight installation of compression type fittings be sure that the tube is inserted to the shoulder in the fitting body and that no dirt or dust is present on tube, ferrules or fittings. Tighten the nut finger tight; while holding the instrument, then tighten the nut 1 turn. If applicable follow the guidelines of the supplier of the fittings.

Special types of fittings are available on request.

The flanges also must fit good to each other and there may not stick seals into the tube.

* **Note:** Always check your system for leaks, before applying fluid pressure. Especially if toxic, explosive or other dangerous fluids are used.

2.7 Piping

BE SURE THAT PIPING IS ABSOLUTELY CLEAN!

DO NOT install small diameter piping on high flowrates, because the inlet jet flow will affect the accuracy.

DO NOT mount abrupt angles direct on in- and outlet, especially not on high flowrates. We recommend at least 10 pipe diameters distance between the angle and the instrument.

DO NOT mount pressure regulators direct on the inlet of gas flow meters/controllers, but allow some meters of piping (at least 25 D). Special attention should be taken at high flow rates with flow controllers. An up- and downstream buffer is needed with a volume calculated according to the following formula:

$$V \geq \frac{0,15 d^2}{\sqrt{\rho}}$$

in which:

V = Volume in litres

d = orifice diameter in mm

ρ = density at normal conditions

$d = 7,6 \sqrt{k_v}$

Example:

Flow controller at 500 l_n/min Air and orifice diameter d = 4 mm, needs for stable control a buffer volume of:

$$V \geq 0,15 \cdot 4^2 : \sqrt{1,29} = 2,1 \text{ litres}$$

Also the capacity of the pressure regulator should be at least 2 times the flow controller, so in this case
 $2 \cdot 500 = 1,000 \text{ l}_n/\text{min}$.

2.8 Electrical connections

Installation advice: to prevent damage to the instrument as result of reversed polarity, Bronkhorst® recommends the use of a 2A fuse in the direct +Us line.

Electrical connection must be made with standard cables or according to the applicable hook-up diagrams. The connections of the factory installed 8 DIN and optional M12 connector are indicated on the hook-up diagram of the instrument. Make sure that the power supply is suitable for the power ratings as indicated on the instrument label and that double or reinforced insulation is used for the power supply.

Applicable hook-up diagrams for IN-FLOW can be found at: <http://www.bronkhorst.com/en/downloads>
 IN-FLOW instruments are powered with +15...+24 Vdc.

Do not power the instrument simultaneously from two different power sources (e.g. bus connection and Plug-in Power Supply (PIPS)). Doing so will blow the fuse on the pc-board, requiring the return of the instrument for repair.

To comply with the IP classification it is necessary to follow the assemble guidelines of the connector manufacturer. To lock the 8 DIN / M12 cable connector to the equipment connector, the threaded ring is tightened until it is 'finger-tight' (approx. 50 cNm).

The instruments contain electronic components that are susceptible to damage by electrostatic discharge. Proper handling procedures must be taken during installation, removing and connecting the electronics.

The instruments described in this manual carry the CE-mark and are compliant with the EMC requirements. However compliance with the EMC requirements is not possible without the use of proper cables and connector/gland assemblies.

Bronkhorst recommends the use of their standard cables. These cables have the right connectors and if loose ends are used, these will be marked to prevent wrong connection. When using other cables, cable wire diameters should be sufficient to carry the supply current and voltage losses must be kept as low as possible. When in doubt: contact your distributor. When connecting the system to other devices (e.g. PLC), be sure that the integrity of the shielding is not affected. Do not use unshielded wire terminals.

2.8.1 Disconnection from supply source

Bronkhorst recommends to use a circuit breaker or switch being installed in the end application.

2.9 *Caution*

Each meter/controller is pressure tested to at least 1.5 times the working pressure of the process conditions stipulated by the customer, with a minimum of 8 bar.

For pressure meter/controllers. The test pressure depends on the range of the pressure transducer.

In general 2 x F.S. value for ranges 1 and 2 bar
 1.5 x F.S. value for ranges up to 200 bar
 1.25 x F.S. value for ranges up to 400 bar

The tested pressure is stated on the flow meter/controller with a RED COLOURED sticker. Check test pressure before installing in the line.

If the sticker is **not** available or the test pressure is incorrect, the instrument should **not** be mounted in the process line and be returned to the factory.

Each instrument is helium leak tested to at least $2 \cdot 10^{-9}$ mbar l/s Helium.

2.10 *Supply pressure*

Do not apply pressure until electrical connections are made. When applying pressure to the system, take care to avoid pressure shocks in the system and increase pressure gradually, especially on high pressure units incorporating a piston operated control valve.

For instruments used above 10 barg:

Bronkhorst recommends a maximum decompression rate of 70 bar/min, according NACE TM0297.

Exceeding this rate can have negative influence on the lifetime of the sealing materials.

2.11 *System purging*

If explosive gases are to be used, purge the process with inert dry gas like Nitrogen, Argon etc. for at least 30 minutes.

In systems with corrosive or reactive fluids, purging with an inert gas is absolutely necessary, because if the tubing has been exposed to air, introducing these fluids will tend to clog up or corrode the system due to a chemical reaction with oxygen or moist air.

Complete purging is also required to remove such fluids from the system before exposing the system to air. It is preferred not to expose the system to air, when working with these corrosive fluids.

2.12 *Seals*

Bronkhorst has gathered a material compatibility chart from a number of sources believed to be reliable. However, it is a general guide only. Operating conditions may substantially change the accuracy of this guide. Therefore there is no liability for damages accruing from the use of this guide.

The customers application will demand its own specific design or test evaluation for optimum reliability. So check if the seals like O-rings, plunger and packing gland of capillary are correct for the process.

2.13 Equipment storage

The equipment should be stored in its original packing in a cupboard warehouse or similar. Care should be taken not to subject the equipment to excessive temperatures or humidity.

2.14 Electromagnetic compatibility

2.14.1 Conditions for compliance with EMC requirements

All instruments described in this manual carry the CE-mark.

Therefore they have to comply with the EMC requirements as are valid for these instruments.

However compliance with the EMC requirements is not possible without the use of proper cables and connector/gland assemblies.

For good results Bronkhorst® can provide standard cables. Otherwise follow the guidelines as stated below.

D-Connector assembly

Fold the shield of the cable back over the cable (the shield must be around the cable).

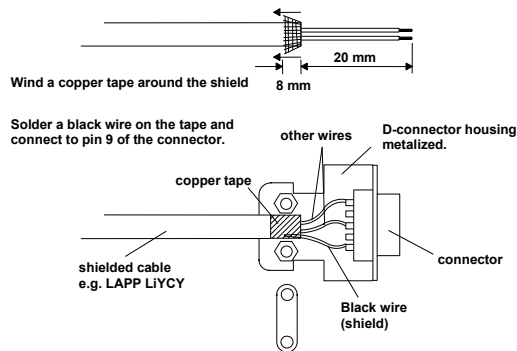

8DIN connector assembly

8 DIN connector Amphenol
Serie C091 31D008 200 2

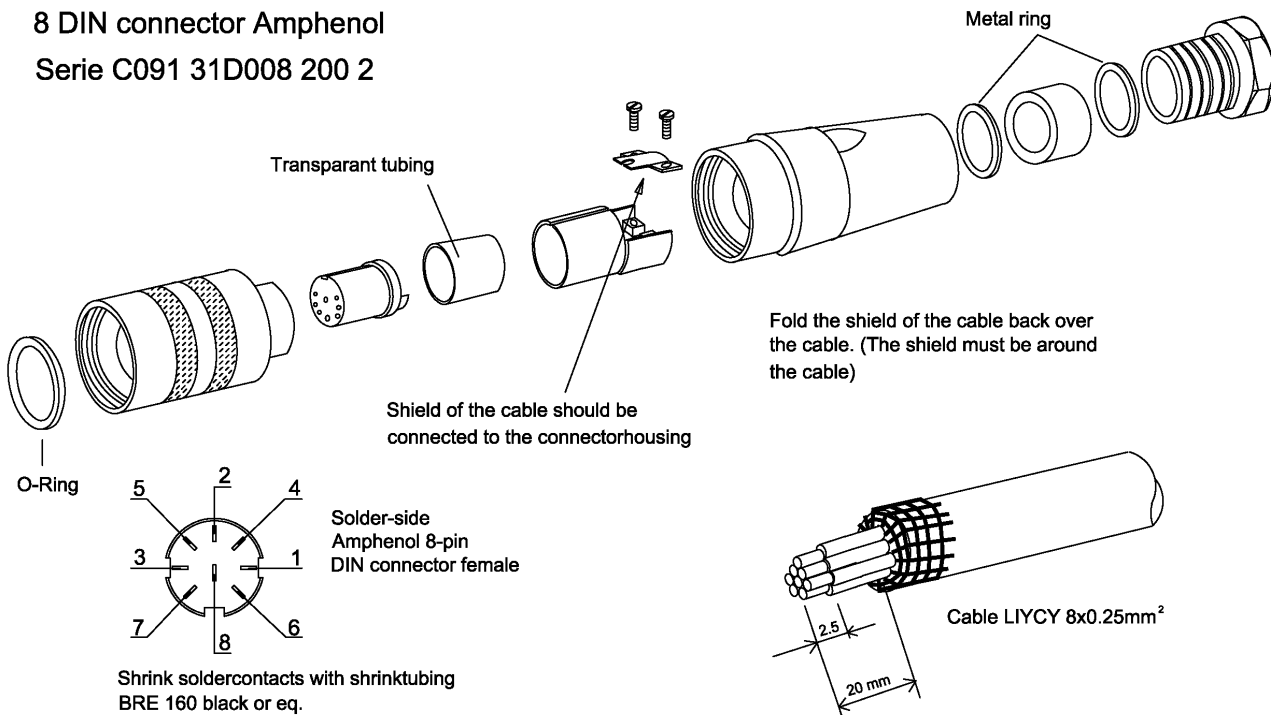

8 DIN Connector Binder
Serie 423 99.5672.19.08

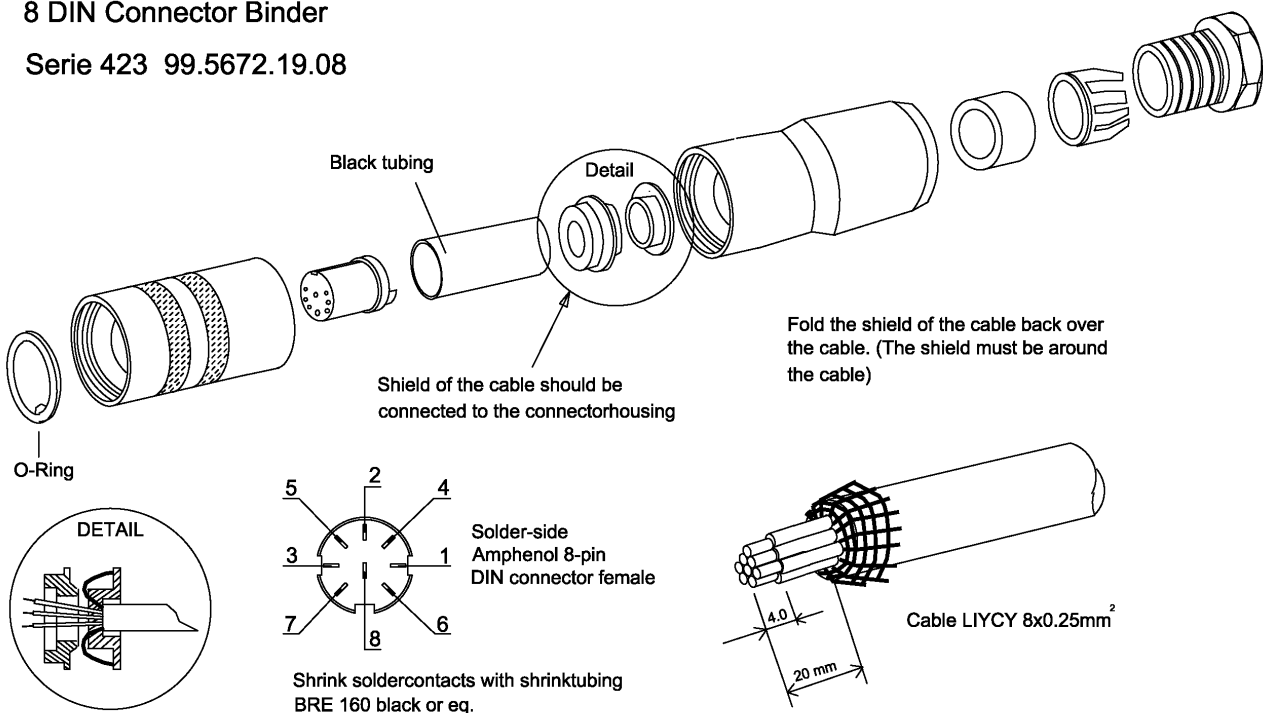

Notes:

1. When connecting the system to other devices (e.g. to PLC), be sure that the integrity of the shielding is not affected. Do not use unshielded wire terminals.
2. For FLOW-BUS S(F)TP data (patch) cable connection to RJ45 connectors follow the instructions of the supplier. It is important to use shielded twisted pair cables and shielded RJ45 modular jack connectors.
3. For PROFIBUS DP or DeviceNet data cable connections follow the instructions of the cable suppliers for the specific field-bus system.

3 OPERATION

3.1 General

The Bronkhorst® instruments are designed in such a way that they will meet user process requirements in the best possible way.

Basically all digital meters/controllers are powered with +15 Vdc to +24 Vdc.

When providing your own power supply, be sure that voltage and current ratings are according to the specifications on the instrument(s) label. A double or reinforced insulation power supply must be used.

When providing your own power supply be sure that voltage and current rating are according to the specifications of the instrument(s) and furthermore that the source is capable of delivering enough energy to the instrument(s).

Cable wire diameters should be sufficient to carry the supply current and voltage losses must be kept as low as possible. When in doubt: consult factory.

Digital instruments can be operated by means of:

1. Analog interface (0...5 Vdc/0...10 Vdc/0...20 mA/4...20 mA)
2. RS232 interface (connected to COM-port by means of special cable)
3. FLOW-BUS
4. PROFIBUS DP
5. DeviceNet
6. Modbus ASCII / RTU / TCP
7. EtherCAT
8. PROFINET
9. CANopen
10. EtherNet/IP
11. POWERLINK

Option 1 and 2 are always present on multibus instruments. An interface to any available fieldbus is optional. Operation via analog interface, RS232 interface and an optional fieldbus can be performed at the same time. A special parameter called "control mode" indicates to which setpoint the controller should listen: analog or digital (via fieldbus or RS232). The RS232 interface behaves like a FLOW-BUS interface.

When using more interfaces at the same time, reading can be done simultaneously without problems.

When changing a parameter value, the last value send by an interface will be valid.

Also the micro push-button switch and the LED's on top of the instrument can be used for manual operation of some options.

The green LED will indicate in what **mode** the instrument is active.

The red LED will indicate **error/warning** situations.

3.2 Power and warm-up

Before switching on power check if all connections have been made according to the hook-up diagram which belongs to the instrument.

It is recommended to turn on power before applying pressure on the instrument and to switch off power after removing pressure.

Check fluid connections and make sure there is no leakage. If needed purge the system with a proper fluid. For a gas instrument only purging with gases is allowed. Liquid instruments may be purged with either a gas or a liquid, whatever is needed for the purpose.

Turn on power and allow at least 30 minutes to warm up and stabilize. In cases where no electronics are involved (valves only) warming up is not needed.

During warm-up period, fluid pressure may either be on or off.

3.3 Zeroing

In general the zero point of each instrument is factory adjusted. If so required the zero point of the instrument may be re-adjusted.

After warm-up, with no gas flow, use the micro push-button switch on top of the instrument to start the automatic zero adjustment procedure, if required.

For flow controllers setpoint must be zero. Be sure there is no fluid flow.

For information how to start the automatic zero procedure by means of the micro push-button switch, see manual operation, document number 9.17.023.

It is also possible to start the automatic zero adjustment procedure through the FLOW-BUS, using a readout/control unit or a software program on a PC, connected to a FLOW-BUS interface module.

See the appropriate documentation for more detailed information.

3.4 Start-up

Turn on fluid supply gently. Avoid pressure shocks, and bring the instrument gradually up to the level of the actual operating conditions. Also switch off fluid supply gently. In case of liquid control be sure to remove all trapped gas bubbles from the system. The purge connection on top of the control valve can be used for this purpose.

3.5 Operating conditions

Each instrument has been calibrated and adjusted for customer process conditions.

Controllers or valves may not operate correctly, if process conditions vary too much, because of the restriction of the orifice in the valve.

For flowmeters performance and accuracy may be affected tremendously if physical fluid properties such as heat capacity and viscosity change due to changing process conditions.

3.6 Instrument performance

3.6.1 Sensors

Assuming that the transfer function of a system is an exponential shaped curve, the time constant is defined as follows:

time constant = time for the signal to reach 63.2 % of its final output value. Approx. five time constants is the time to reach the final value.

The time constant of flow sensors depends on the type of instrument and settings.

Pressure sensors have a time constant of some milliseconds. However the actual response is determined by the pneumatic response of the system which the pressure meter is part of.

3.6.2 Controllers

The dynamic response of a controller is factory set. Standard settling time is defined as the time to reach the setpoint (and stay) within $\pm 2\%$ of the initial setpoint.

The control mode is factory set in such a way that after a step change, there will be little overshoot.

Note:

In pressure control systems the system widely determines the response behaviour of the control loop. During testing the customer system is simulated as closely as possible. In some cases however readjustment is needed for optimum performance under actual conditions.

3.7 Manual operation

By means of manual operation of the micro push-button switch some important actions for the instrument can be selected/started. These options are available in both analog or BUS/digital operation mode. (see also manual operation in document number 9.17.023)

These functions are:

- reset (instrument firmware-program reset)
- auto-zeroing (remove zero-drift offset in sensor bridge)
- restore factory settings (in case of unintended change of the settings)

for FLOW-BUS only:

- automatic installation to FLOW-BUS (installs instrument to free address)
- remote installation to FLOW-BUS (instruments will be installed by PC-software)

3.8 Analog operation

Digital instruments can be operated with analog signals through the 9-pin sub-D connector or 8DIN connector. The instruments are compatible in use with **analog** instruments on this point. Analog operated instruments can be hooked-up using an 8-wire shielded cable with 9-pin D-connectors or 8DIN connectors, connected according to the Bronkhorst® standard.

Each electronic p.c.board is set for one of the following output (and corresponding input) signals:

Signal code	output (sensor) signal	input (setpoint) signal
A	0...5 Vdc	0...5 Vdc
B	0...10 Vdc	0...10 Vdc
F	0...20 mA (sourcing)	0...20 mA (sinking)
G	4...20 mA (sourcing)	4...20 mA (sinking)

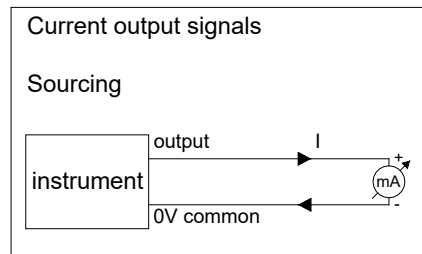

For meters only the output signal is available.

At analog operation following parameters are available:

- measured value
- setpoint (controllers only)
- valve voltage (controllers only)

Note:

When operating the instrument through the analog interface it is possible to connect the instrument to any supported fieldbus system (or RS232-interface with special cable) for reading/changing parameters (e.g. controller response or other fluid selection).

For FLOW-BUS versions of the instruments a readout/control module for digital instruments can be temporarily connected to the RJ45 modular jack plug.

3.9 **BUS / digital operation**

Operation via fieldbus reduces the amount of cables to build a system of several instruments and offers more parameter values to be monitored/changed by the user.

See instruction manual: operating digital mass flow / pressure instruments for more details (document nr. 9.17.023).

Operation by means of a fieldbus adds a lot of extra features (compared to analog operation) to the instruments.

Such as:

- setpoint slope (ramp function on setpoint for smooth control)
- 8 selectable fluids (calibration settings for high accuracy)
- direct reading at readout/control module or host computer
- testing and self diagnosis
- response alarm ($|\text{setpoint-measure}|$ too high for too long time)
- several control/setpoint modes (e.g. purge/close valve)
- master/slave modes for ratio control (FLOW-BUS only)
- identification (serial number, model number, device type, user tag)
- adjustable minimal and maximal alarm limits
- (batch) counter
- adjustable response time for controller when opening from zero
- adjustable response time for normal control
- adjustable response time for stable control ($|\text{setpoint-measure}| < 2\%$)

Note:

Special RS232 cable consists of a T-part with 1 male and 1 female sub-D 9 connector / 8DIN connector on one instrument-side and a normal female sub-D 9 connector on the side of the computer. See hook-up diagram for the correct RS232 cable which should be used.

By means of this cable it is possible to offer RS232 communication and still be able to connect power-supply and analog interface through the (analog) sub-D 9 connector / 8DIN connector.

RS232 communication is possible with a baudrate of 38400 Baud (default baudrate) and can be used for either:

- Uploading new firmware by means of a special program (for trained BHT-service personnel only)
- Servicing your instrument using BHT-service programs (for trained BHT-service personnel only)
- Operating your instrument using FLOWDDE, FLOWB32.DLL or RS232-ASCII protocol (end user)

4 Maintenance

4.1 General

At normal use, no routine maintenance is required to be performed on the meters or controllers. Units may be flushed with clean, dry inert gas.

For further information contact supplier or factory.

4.2 Gas flow sensor

The gas flow sensor is constructed in such a way that for a change in range, the laminar flow element can be removed. It is not recommended for the user to disassemble the instrument other than for removing the laminar flow element for inspection, or range changing only. After replacing the laminar flow element it becomes necessary to recalibrate the flow meter. When doing so proceed according to a suitable calibration procedure. Depending on the model number laminar flow elements can be ordered separately.

4.3 Liquid flow sensor

The user cannot change the flow range of a liquid flow sensor. The sensor is an integral part of the instrument and cannot be removed from it. For occasional cleaning the instrument may be flushed with a cleaning fluid.

4.4 Pressure sensor

It is not recommended for the user to disassemble the pressure sensor, because the thin metal membrane is very delicate.

4.5 Controllers

All sensor types can be combined with a control valve to be operated together as a control loop. Controller systems are either available as separate units; a sensor and a control valve, or as an integrated unit. If applicable maintenance procedures are described under "control valves"

4.6 Control valves

Control valves cannot be used for shut-off and/or on-off applications. Pressure surges, as may occur during system pressurisation or deflation must be avoided.

4.6.1 Solenoid valves

These are considered to be the direct operated control and pilot valves.

Instruments (meter and/or valve) need no regular maintenance if operated properly, with clean media, compatible with the wetted materials, avoiding pressure and thermal shocks and vibrations. Units may be purged with a clean, dry and inert gas (for gas instruments) or a non-aggressive and non-corrosive solvent (for liquid instruments).

In case of severe contamination, cleaning of the inside of the instrument and of the valve orifice (if applicable) may be required. After cleaning, recalibration of the instrument is recommended.

Inexpertly servicing instruments can lead to serious personal injury and/or damage to the instrument or the system it is used in. Servicing must therefore be performed by trained and qualified personnel. Contact your Bronkhorst representative for information about cleaning and calibration. Bronkhorst has a trained staff available.

4.6.2 Vary-P valve

The vary-P valve is designed to cope with extremely varying process conditions on either upstream or downstream side of the valve or a combination of these. Δp can vary over a wide range. The basic control valve is a direct operated solenoid control valve.

The design has been patented.

For orifice selection and maintenance other than the pilot valve consult the factory.

4.6.3 Pilot operated valve

This control valve is an indirect control valve, consisting of a spring loaded membrane/orifice system which is positioned by a solenoid operated direct control (pilot valve). The two devices are integrated in one block.

Basically follow the same procedures for dis-assembly as stipulated under "Solenoid valves"

For cleaning purposes it may be required to dis-assemble further, i.e. also remove the membrane assembly.

Note:

When pressure testing a system incorporating a pilot operated control valve, a special procedure must be followed in order to prevent damage to the valve. In such cases it is necessary to contact the factory prior to do this.

4.6.4 Bellows valve

These valves are suited for low pressure or vacuum applications. Preferably this model should not be disassembled by the user.

Bronkhorst® strongly advises to mount the bellows valves in an upright position.

4.7 *Calibration procedure*

All instruments are factory calibrated. For re-calibration or re-ranging contact supplier or factory.

4.8 *Cleaning*

Cleaning of the instrument may only be done by a dry cloth.

5 Digital instrument

See document number 9.17.023 for detailed description.

This document is available as PDF on the Multibus documentation/software tool CD.

6 Interface description

For a description of the available interfaces see document numbers:

9.17.024 for FLOW-BUS
9.17.025 for PROFIBUS DP
9.17.026 for DeviceNet
9.17.027 for RS232
9.17.035 for Modbus ASCII / RTU / TCP
9.17.063 for EtherCAT
9.17.095 for PROFINET
9.17.131 for CANopen
9.17.132 for EtherNet/IP
9.17.142 for POWERLINK

These documents are available as PDF on the Multibus documentation/software tool CD.

7 TROUBLESHOOTING

7.1 General

For a correct analysis of the proper operation of a flow/pressure meter or controller it is recommended to remove the unit from the process line and check it without applying fluid supply pressure. In case the unit is dirty, this can be ascertained immediately by loosening the compression type couplings and, if applicable the flange on the inlet side.

Bronkhorst does not recommend to open the housing, but in case that the housing has to be opened, it should be done with great care, because the connection of the fieldbus and main p.c.board is accomplished by a small flat conductor cable.

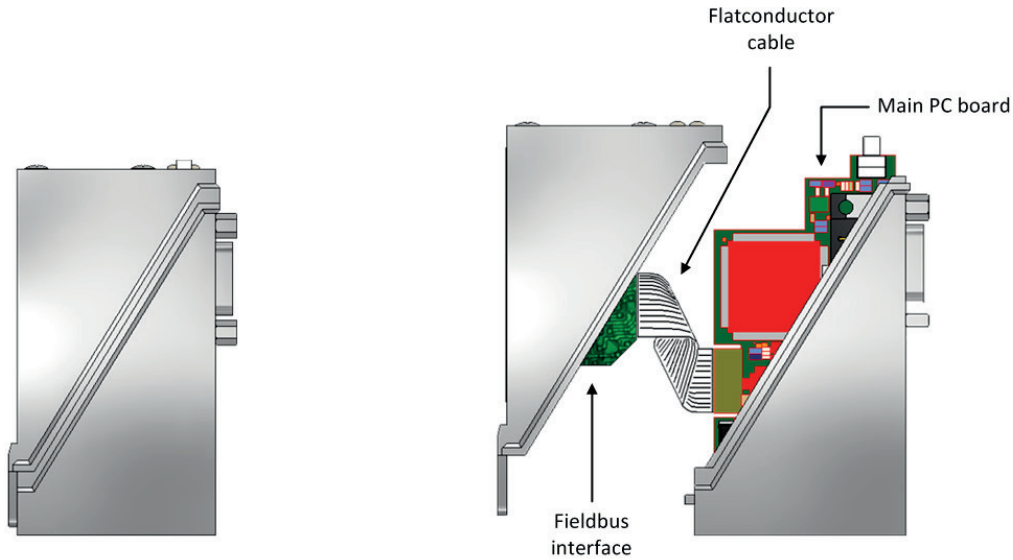

Energizing or de-energizing of the instrument of the instrument indicates whether there is an electronic failure.

After that, fluid pressure is to be applied in order to check behaviour.

If there should be suspicion of leakage, do not check for bubbles with a leak detection liquid as this may lead to a short-circuit in the sensor or p.c.board.

7.2 Troubleshooting summary general

Symptom	Possible cause	Action
No output signal	No power supply	1a) check power supply 1b) check cable connection
	Output stage blown-up due to long lasting shortage and/or high-voltage peaks	1c) return to factory
	Supply pressure too high, or differential pressure across meter too high	1d) lower supply pressure
	Valve blocked/contaminated	1e) connect 0 .. 15 Vdc to valve and slowly increase voltage while supply pressure is 'on'. The valve should open at $7V \pm 3V$; if not open, then cleaning parts and adjust valve (qualified personnel only)
	Screen in inlet fitting blocked	1f) clean screen
	Sensor/capillary failure	1g) return to factory
Maximum output signal	Output stage blown-up	2a) return to factory
	Sensor/capillary failure	2b) return to factory
Output signal much lower than setpoint signal or desired flow	Screen blocked/contaminated	3a) clean screen
	LFD blocked/contaminated and/or liquid in meter	3b) remove LFD and clean; dry meter with air or N ₂
	Valve blocked/contaminated	3c) clean valve
	Valve internals damage (swollen seat in plunger)	3d) replace plunger assembly and adjust valve or return
	Incorrect type of gas is used and/or pressure/diff. pressure	3e) try instrument on conditions for which it was designed
Flow is gradually decreasing	Condensation, occurs with NH ₃ , hydrocarbons such as C ₃ H ₈ , C ₄ H ₁₀ etc.	4a) decrease supply pressure and/or heat gas to be measured
	Valve adjustment has changed	4b) see '1e'
Oscillation	Supply pressure/diff. pressure too high	5a) lower pressure
	Pipeline too short between pressure regulator and MFC	5b) increase length or diameter of piping upstream
	Pressure regulator is oscillating	5c) replace pressure regulator or try '5b'
	Valve sleeve or internals damaged	5d) replace damaged parts and adjust valve, see '1e' or return to factory
	Controller adjustment wrong	5e) adjust controller
Small flow at zero setpoint	Valve leaks due to damaged plunger or dirt in orifice	6a) clean orifice and/or, when replacing plunger assembly, see '1e'
	Pressure too high or much too low	6b) apply correct pressure

Note: For other (more specific) problems see also troubleshooting parts in other documents.

APPENDIX 1

GAS CONVERSION TABLE

Doc. no.: 9.02.071

GAS CONVERSION FACTOR

Nr.:	Name:	Symbol	Density ρ_n [g / l] 0°C, 1 atm.	Heat capacity* c_p – cal [cal / g.K] 20°C, 1 atm.	Conversion factor 20°C, 1 atm.
1	Acetylene (Ethyne)	C ₂ H ₂	1.172	0.438	0.61
2	Air	Air	1.293	0.241	1.00
3	Allene (Propadiene)	C ₃ H ₄	1.832	0.392	0.43
4	Ammonia	NH ₃	0.7693	0.524	0.77
5	Argon	Ar	1.784	0.125	1.40
6	Arsine	AsH ₃	3.524	0.133	0.66
7	Boron trichloride	BCl ₃	5.227	0.136	0.44
8	Boron trifluoride	BF ₃	3.044	0.188	0.54
9	Bromine pentafluoride	BrF ₅	7.803	0.156	0.26
10	Butadiene (1,3-)	C ₄ H ₆	2.504	0.405	0.31
11	Butane	C ₄ H ₁₀	2.705	0.457	0.25
12	Butene (1-)	C ₄ H ₈	2.581	0.415	0.29
13	Butene (2-) (Cis)	C ₄ H ₈	2.503	0.387	0.32
14	Butene (2-) (Trans)	C ₄ H ₈	2.503	0.421	0.30
15	Carbonylfluoride	COF ₂	2.983	0.194	0.54
16	Carbonylsulfide	COS	2.724	0.175	0.65
17	Carbon dioxide	CO ₂	1.977	0.213	0.74
18	Carbon disulfide	CS ₂	3.397	0.152	0.60
19	Carbon monoxide	CO	1.25	0.249	1.00
20	Chlorine	Cl ₂	3.218	0.118	0.82
21	Chlorine trifluoride	ClF ₃	4.125	0.188	0.40
22	Cyanogen	C ₂ N ₂	2.376	0.275	0.48
23	Cyanogen chloride	ClCN	2.743	0.185	0.61
24	Cyclopropane	C ₃ H ₆	1.919	0.374	0.43
25	Deuterium	D ₂	0.1798	1.73	1.00
26	Diborane	B ₂ H ₆	1.248	0.577	0.43
27	Dibromo difluoromethane	Br ₂ CF ₂	9.361	0.17	0.20
28	Dichlorosilane	SiH ₂ Cl ₂	4.506	0.17	0.41
29	Dimethylamine	C ₂ H ₆ NH	2.011	0.417	0.37
30	Dimethylpropane (2,2-)	C ₅ H ₁₂	3.219	0.462	0.21
31	Dimethylether	C ₂ H ₆ O	2.105	0.378	0.39
32	Disilane	Si ₂ H ₆	2.857	0.352	0.31
33	Ethane	C ₂ H ₆	1.355	0.468	0.49
34	Ethylene (Ethene)	C ₂ H ₄	1.261	0.414	0.60
35	Ethylene oxide	C ₂ H ₄ O	1.965	0.303	0.52
36	Ethylacetylene (1-Butyne)	C ₄ H ₆	2.413	0.401	0.32
37	Ethylchloride	C ₂ H ₅ Cl	2.878	0.263	0.41
38	Fluorine	F ₂	1.696	0.201	0.91
39	Freon-11	CCl ₃ F	6.129	0.145	0.35
40	Freon-113	C ₂ Cl ₃ F ₃	8.36	0.174	0.21
41	Freon-1132A	C ₂ H ₂ F ₂	2.889	0.244	0.44
42	Freon-114	C ₂ Cl ₂ F ₄	7.626	0.177	0.23
43	Freon-115	C ₂ ClF ₅	7.092	0.182	0.24
44	Freon-116	C ₂ F ₆	6.251	0.2	0.25
45	Freon-12	CCl ₂ F ₂	5.547	0.153	0.37
46	Freon-13	CClF ₃	4.72	0.165	0.40
47	Freon-13B1	CBrF ₃	6.768	0.12	0.38
48	Freon-14	CF ₄	3.946	0.18	0.44
49	Freon-21	CHCl ₂ F	4.592	0.154	0.44
50	Freon-22	CHClF ₂	3.936	0.168	0.47
51	Freon-23	CHF ₃	3.156	0.191	0.52
52	Freon-C318	C ₄ F ₈	9.372	0.222	0.15
53	Germane	GeH ₄	3.45	0.16	0.56

* c_p - cal (T,p) = c_p (T + 50°C, p)

GAS CONVERSION FACTOR

Nr.:	Name:	Symbol	Density ρ_n [g / l] 0°C, 1 atm.	Heat capacity* c_p – cal [cal / g.K] 20°C, 1atm.	Conversion factor 20°C, 1atm.
54	Helium	He	0.1785	1.24	1.41
55	Helium (3-)	3He	0.1346	1.606	1.44
56	Hydrogen	H ₂	0.08991	3.44	1.01
57	Hydrogen bromide	HBr	3.646	0.0869	0.98
58	Hydrogen chloride	HCl	1.639	0.192	0.99
59	Hydrogen cyanide	HCN	1.206	0.345	0.75
60	Hydrogen fluoride	HF	0.8926	0.362	0.96
61	Hydrogen iodide	HI	5.799	0.0553	0.97
62	Hydrogen selenide	H ₂ Se	3.663	0.109	0.78
63	Hydrogen sulfide	H ₂ S	1.536	0.246	0.82
64	Isobutane	C ₄ H ₁₀	2.693	0.457	0.25
65	Isobutylene (Isobutene)	C ₄ H ₈	2.60	0.429	0.28
66	Krypton	Kr	3.749	0.058	1.43
67	Methane	CH ₄	0.7175	0.568	0.76
68	Methylacetylene	C ₃ H ₄	1.83	0.399	0.43
69	Methylbromide	CH ₃ Br	4.35	0.118	0.61
70	Methylchloride	CH ₃ Cl	2.3	0.212	0.64
71	Methylfluoride	CH ₃ F	1.534	0.29	0.70
72	Methylmercaptan	CH ₃ SH	2.146	0.272	0.53
73	Molybdenum hexafluoride	MoF ₆	9.366	0.156	0.21
74	Mono-ethylamine	C ₂ H ₅ NH ₂	2.011	0.436	0.36
75	Monomethylamine	CH ₃ NH ₂	1.419	0.424	0.52
76	Neon	Ne	0.9002	0.246	1.41
77	Nitric oxide	NO	1.34	0.239	0.97
78	Nitrogen	N ₂	1.250	0.249	1.00
79	Nitrogen dioxide	NO ₂	2.053	0.204	0.74
80	Nitrogen trifluoride	NF ₃	3.182	0.194	0.50
81	Nitrosyl chloride	NOCl	2.984	0.17	0.61
82	Nitrous oxide	N ₂ O	1.978	0.221	0.71
83	Oxygen	O ₂	1.429	0.222	0.98
84	Oxygen difluoride	OF ₂	2.417	0.201	0.64
85	Ozone	O ₃	2.154	0.207	0.70
86	Pentane	C ₅ H ₁₂	3.219	0.455	0.21
87	Perchlorylfluoride	ClO ₃ F	4.653	0.165	0.41
88	Perfluoropropane	C ₃ F ₈	8.662	0.22	0.16
89	Performa- ethylene	C ₂ F ₄	4.523	0.206	0.33
90	Phosgene	COCl ₂	4.413	0.149	0.47
91	Phosphine	PH ₃	1.53	0.277	0.73
92	Phosphorous pentafluoride	PF ₅	5.694	0.183	0.30
93	Propane	C ₃ H ₈	2.012	0.456	0.34
94	Propylene (Propene)	C ₃ H ₆	1.915	0.408	0.40
95	Silane	SiH ₄	1.443	0.349	0.62
96	Silicon tetrafluoride	SiF ₄	4.683	0.18	0.37
97	Sulfurylfluoride	SO ₂ F ₂	4.631	0.175	0.38
98	Sulfur dioxide	SO ₂	2.922	0.157	0.68
99	Sulfur hexafluoride	SF ₆	6.626	0.175	0.27
100	Sulfur tetrafluoride	SF ₄	4.821	0.192	0.34
101	Trichlorosilane	SiHCl ₃	6.044	0.157	0.33
102	Trimethylamine	C ₃ H ₉ N	2.637	0.424	0.28
103	Tungsten hexafluoride	WF ₆	13.29	0.092	0.25
104	Vinylbromide	C ₂ H ₃ Br	4.772	0.141	0.46
105	Vinylchloride	C ₂ H ₃ Cl	2.865	0.229	0.47
106	Vinylfluoride	C ₂ H ₃ F	2.08	0.305	0.49
107	Xenon	Xe	5.899	0.0382	1.38

* c_p - cal (T,p) = $c_p(T + 50^\circ\text{C}, p)$